

TUBO Ø 1/4  
PIPE Ø 1/4

OUTLET

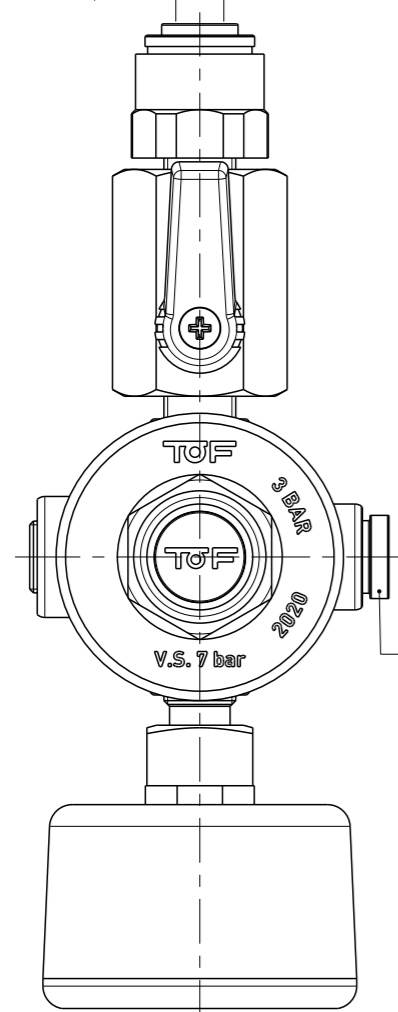

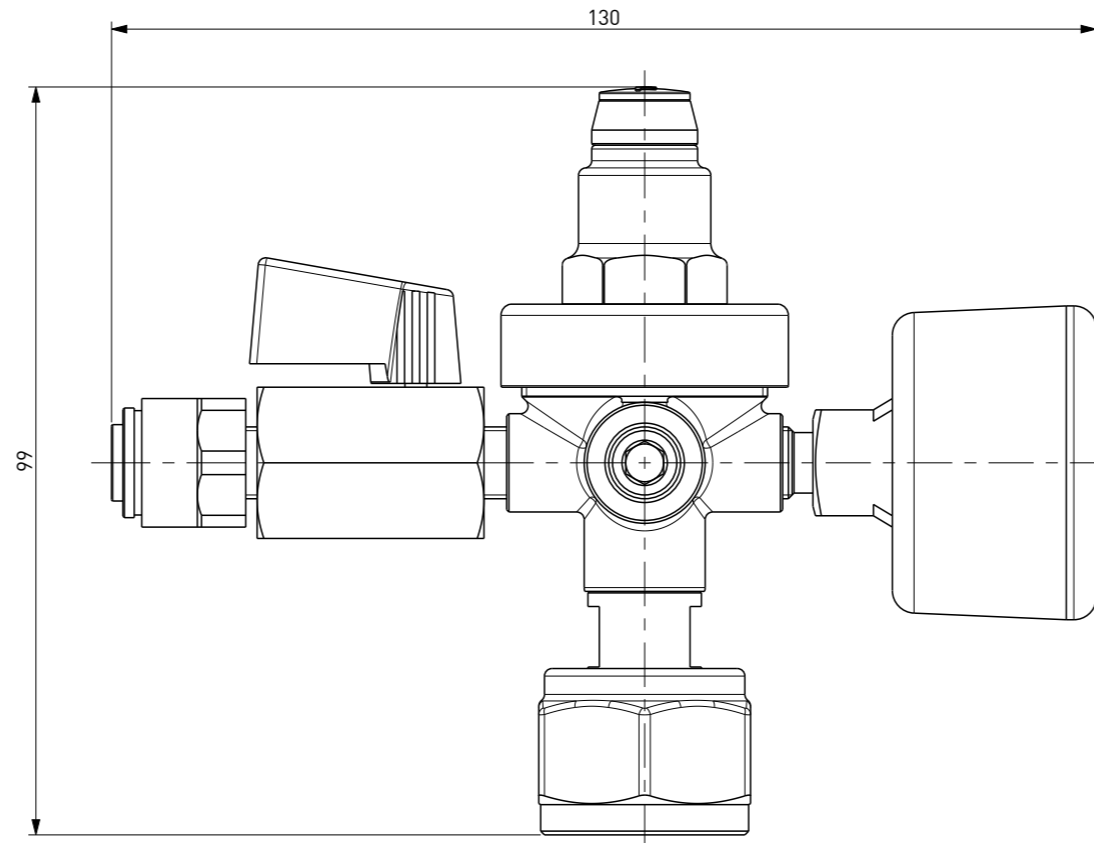

TARATURA VALVOLA DI SICUREZZA: 7 BAR  
SAFETY VALVE CALIBRATION: 7 BAR

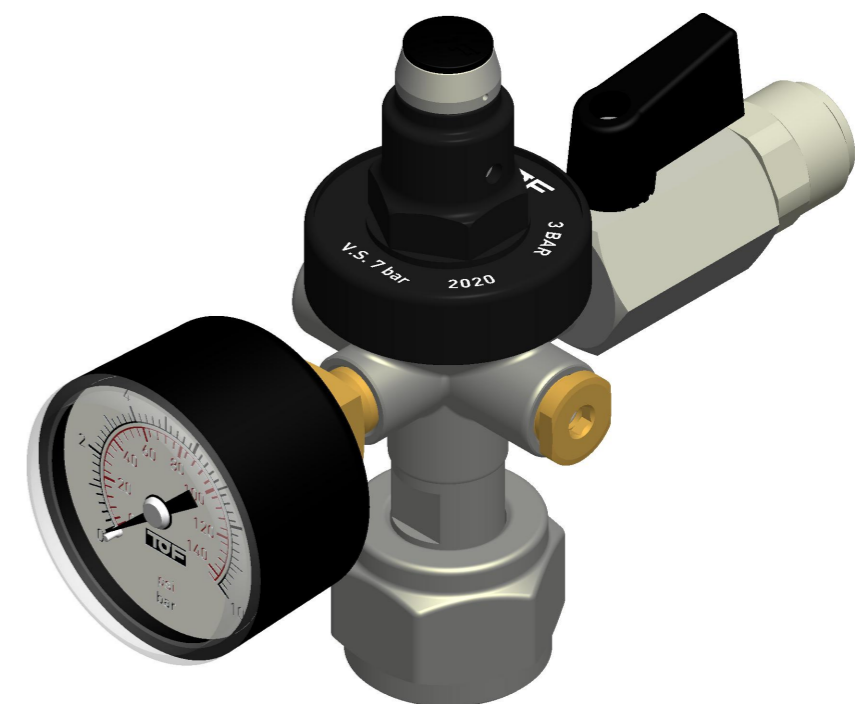

ATTACCO BOMBOLA SECONDO NORMA BS341 N°8  
MAX PRESSIONE DI INGRESSO= 120 BAR  
TARATURA FISSA RIDUTTORE= 3 BAR ±0,5  
INIZIO SFIATO VALVOLA DI SICUREZZA= 7 BAR +0,5  
MAX SOVRAPRESSIONE= +8%

CYLINDER CONNECTION ACCORDING BS341 N°8  
MAX INLET PRESSURE= 120 BAR  
LOCKED PRESSURE REGULATION= 3 BAR ±0,5  
SAFETY VALVE INITIAL RELIEF= 7 BAR +0,5  
MAX OVERPRESSURE= +8%



FILE: 27_070U8B70ZT	DISEGNO DI PROPRIETA' RISERVATA A TUTTI GLI EFFETTI DI LEGGE		 ITALIAN MANUFACTURERS SINCE 1948		
ARCHIVIO: //					
REPARTO: MON-B	TOLLERANZE UNI EN ISO 22768-F TRANNE DOVE DIVERSAMENTE INDICATO		○ QUOTE IMPORTANTI	① ESPONENTE DI MODIFICA	
SCALA: 1:1	MATERIALE: DIVERSI / VARIOUS				
NORMATIVE:		GRUPPO			
DIS.N°: 27/70U10B70ZT		- RIDUTTORE DI PRESSIONE / PRESSURE REDUCER			
- RIDUTTORE XS - 3 BAR FISSO - V.S. 7 BAR - 1 UTENZA J.GUEST Ø1/4 CON VALVOLA A SFERA - 0.860\"/>					
- XS PRESSURE REDUCER - 3 BAR LOCKED - V.S. 7 BAR - 1 OUTLET J.GUEST Ø1/4 WITH BALL VALVE - 0.860\"/>					
Rev.	DATA	DESCRIZIONE	DIS.	DEL.	PEZZO GREZZO Kg :
0	24-11-2020	EMISSIONE / EMISSION	BR	TD	PEZZO FINITO Kg : 0.354
PRIMA EMISSIONE: 24-11-2020					DISEGNO STAMPO:
NOTE:					FORMATO: A3
					FOGLIO: 1