

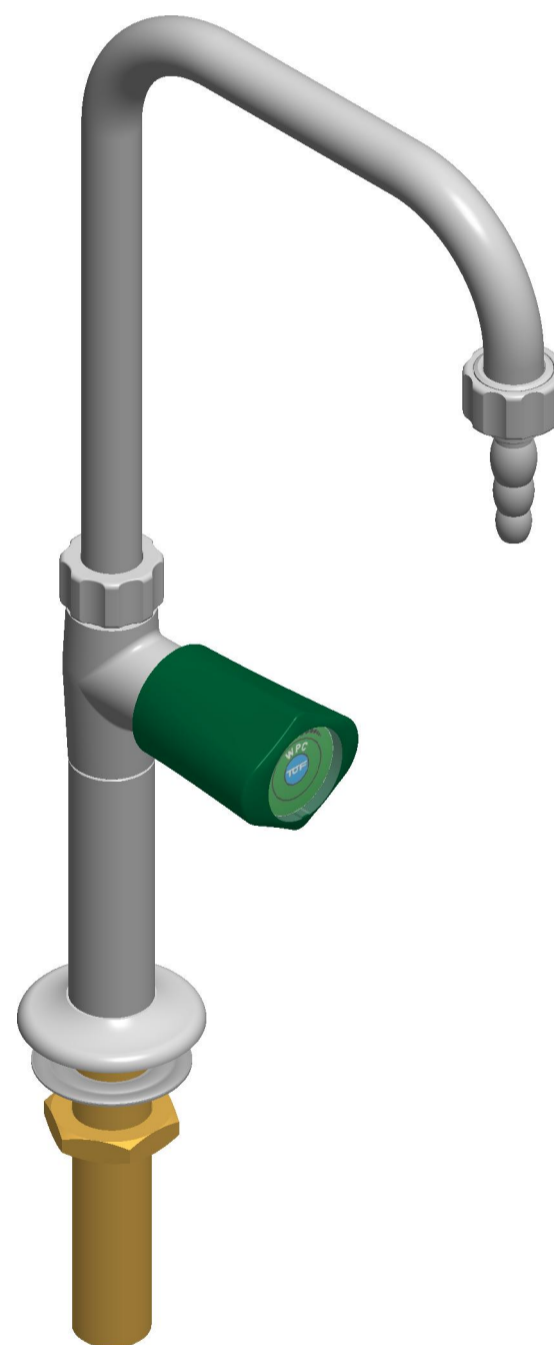

NOTE:

- FILETTO FISSAGGIO SECONDO NORMA UNI EN ISO 228/1
- BECCUCCIO SECONDO NORMA DIN12898
- CODICE COLORE SECONDO NORMA DIN EN 13792
- PRESSIONE MAX. DI LAVORO 10BAR/145PSI
- THREAD CONNECTION ACCORDING UNI EN ISO 228/1
- NOZZLE ACCORDING DIN12898
- COLOR CODE ACCORDING DIN EN 13792
- MAX. WORKING PRESSURE 10BAR/145PSI



FILE: 1000_270-BO		DISEGNO DI PROPRIETA' RISERVATA A TUTTI GLI EFFETTI DI LEGGE			 ITALIAN MANUFACTURERS SINCE 1948
ARCHIVIO: //					
REPARTO: MON-L	TOLLERANZE UNI EN ISO 22768-F TRANNE DOVE DIVERSAMENTE INDICATO		○ QUOTE IMPORTANTI		
SCALA: 1:2			Ⓝ ESPONENTE DI MODIFICA		
MATERIALE: DIVERSI/VARIOUS					
NORMATIVE:					
<b>DIS.N°: 1000/270-BO</b>			GRUPPO		
			- RUBINETTERIA PER ACQUA/TAPS FOR WATER		
- COLLO DI CIGNO CON RUBINETTO - G1/2" - BECCUCCIO OTTONE					
- SWIDEL GOOSENECK WITH TAP - G1/2" - BRASS NOZZLE					
Rev.	DATA	DESCRIZIONE	DIS.	DEL.	PEZZO GREZZO Kg :
7	28-04-2015	AGGIORNAMENTO GRAFICO/GRAPHIC UPDATE	AA	TD	PEZZO FINITO Kg : 1.109
PRIMA EMISSIONE: 09-03-2000					DISEGNO STAMPO:
NOTE:					FORMATO: A3   FOGLIO: 2